

847 Series

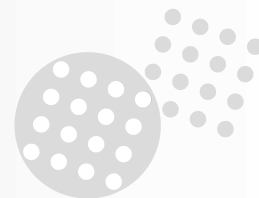

Applications

Power supply (up to 63 A)

Standards

VG 96918

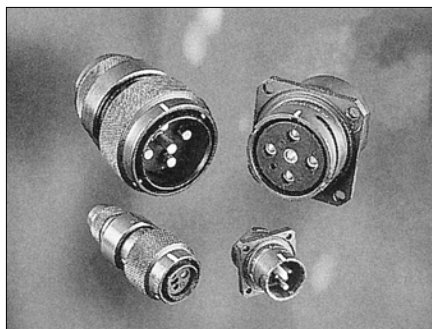

Description

- Bayonet coupling connector with crimp contacts
- Pilot and ground contacts available
- Contact layouts for :
 - mono 220 V
 - tri 220/380 + N + Pilot
- Shell continuity by grounding fingers.

Characteristics

Environmental

- Temperature range : - 55°C to + 85°C (125°C peak)
- Sealing (immersion) : 1 bar - 12 hours
- Salt spray resistance : 48 hours

Mechanical

- Shell : steel
- Backshell : steel
- Insulator : elastomer made in one piece
- Contacts : crimp, machined, from brass
- Plating : shells and backshells :
 - olive green cadmium
 - white cadmium
- contacts and shielding bracelet :
 - silver
- Endurance : 500 mating/unmating operations

Electrical

- Operating voltage :
 - shell 2 : 250 Vrms
 - shells 4-5 : 380 Vrms
- Current rating :
 - shell 2 : 16 A
 - shell 4 : 25 A
 - shell 5 : 63 A
- Withstanding voltage : 2000 Veff

Ordering information (with contacts and backshells)

basic series	847	48	F	5	47	N	3	02
contact layout	25-48-58							
shell type	A : square flange receptacle, smooth holes, without thread for backfitting B : square flange receptacle, smooth holes, with thread for backfitting L : square flange receptacle, threaded holes, without thread for backfitting M : square flange receptacle, threaded holes, with thread for backfitting F : plug P : cable connecting receptacle D : jam nut receptacle with thread for backfitting R : jam nut receptacle without thread for backfitting							
contact type	1 : crimp male contact 5 : crimp female contact							
backshell type	00 : receptacles (A, L, R types), without thread for backfitting receptacles (B, M, D), plugs and cable connecting receptacles supplied without backshell 21 : straight cable clamp and sealing gland backshell 23 : elbow cable clamp and sealing gland backshell 47 : straight backshell for shield termination and heatshrink sleeving 48 : straight backshell for shield termination and heatshrink sleeving and tightening shield ring							
orientation	N, W, X, Y : in all cases (orientation during the wiring operation)							
insert type ^{① ② ③}	0 : without grommet, without pilot contact 1 : with grommet, without pilot contact 2 : without grommet, with pilot contact 3 : with grommet, with pilot contact		① contact layout 25 : inserts are without pilot contact ② contact layout 58 : inserts are only with grommet ③ contact layouts 25 and 48 : with or without pilot contact Filler plug is supplied					
specifications	02 : olive green cadmium 03 : olive green cadmium with specific contacts 09 : white cadmium							

847 Series



Contact layouts and polarizations

viewed from front face of male insulator

contact layout 25 - MONO 220 V + ⊕

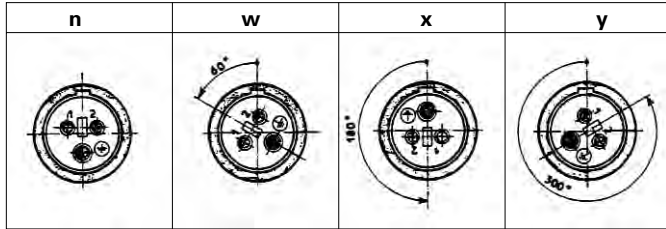

contact layout 48 TRI 220/380 V + N + Pilot + ⊕

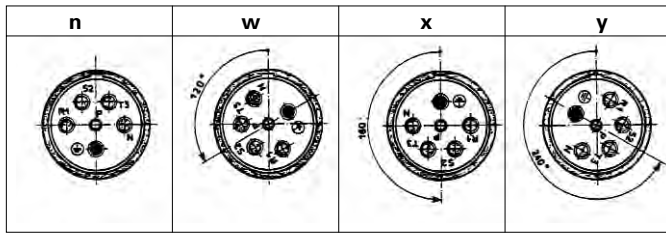

contact layout 58 TRI 220/380 V + N + Pilot ⊕

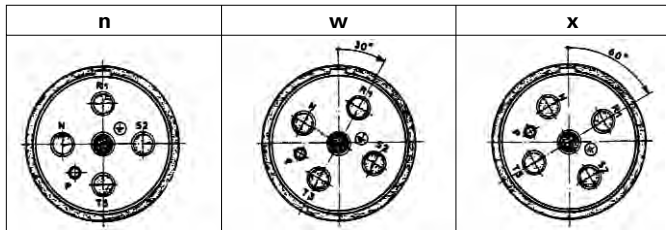

Contacts

(only for 02 and 09 spec.)

		contact layouts		
		25	48	58
male contact	phase	8400.2311	8400.2182	8400.2322
	ground	8400.2181	8400.2183	8400.2323 ^①
	pilot	-	8400.2312	
female contact	phase	8400.2313	8400.2214	8400.2321
	ground	8400.2213	8400.2215	8400.2324 ^①
	pilot	-	8400.2216	
	filler plug ^②	-	8522.389A	
	reducing ^③ sleeve	-	8400.3506 ^④	8400.2315 ^⑤ 8400.2327 ^⑤

^① Contact in two parts : contact body and crimping tip

^② Insure sealing for version without pilot contact

^③ to order separately

^④ for wire section 0.93 mm²

^⑤ for wire section 5.30 mm²

^⑥ for wire section 8.98 mm²

usable for phase
and ground contacts

Dimensions

Square flange receptacle, smooth or threaded holes without thread for backfitting

A and L types

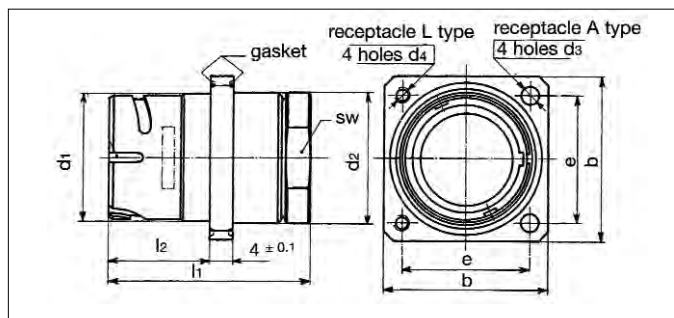

shell	d1 Max	d2 Max	d3	d4	l1 Max	l2 Max	e	b Max	sw
2	20.5 .807	22 .866	3.2 .126	M3	33.5 1.319	16.6 .654	21 .827	27 1.063	19 .748
4	31.5 1.240	32.8 1.291	5.5 .217	M5	35.6 1.402	17.5 .689	33 1.299	42 1.654	30 1.181
5	43.1 1.697	45 1.772	5.5 .217	M5	49 1.929	18.8 .740	43 1.693	54 2.126	42 1.654

Panel cut-out

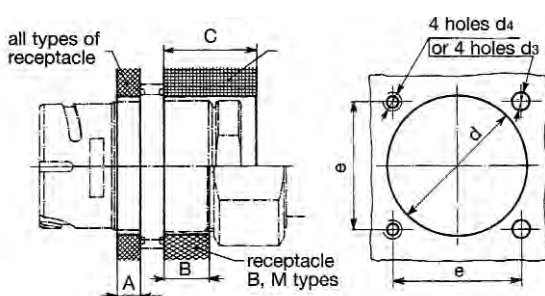

shell	A Max	B Max	C Max	d	e	d3	d4
2	3.75 .148	6.5 .256	illimited	23 .906	21 .827	3.2 .126	M3
4	4.0 .157	6.5 .256	illimited	34 1.339	33 1.299	5.5 .217	M5
5	5.75 .226	6.5 .256	illimited	46 1.811	43 1.693	5.5 .217	M5

847 Series



Square flange receptacle, smooth or threaded holes, with thread for backfitting B and M types

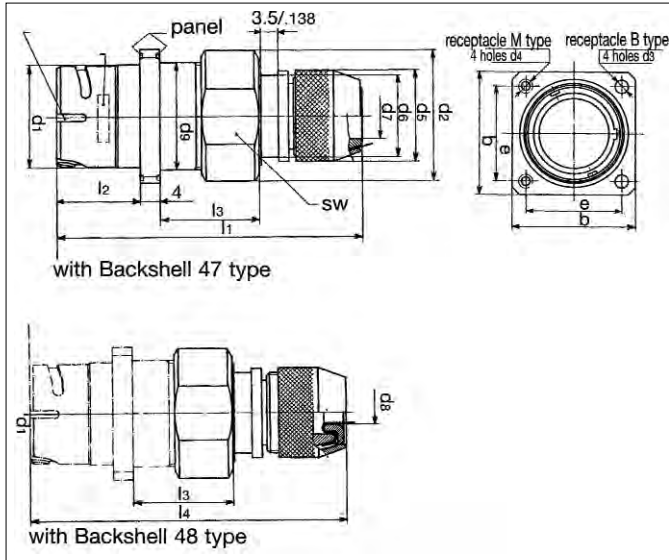

shell	d2 Max	d5 Max	d6	d7	d8	d9 Max	l1 Max	l3 Max	l4 Max	sw
2	26.1 1.028	18.1 .713	16.1 .634	9.2 .362	- -	21.5 .846	61.2 2.409	20.3 .799	- -	24 .945
4	38.6 1.520	28.1 1.106	26.2 1.031	18.3 .720	12.8 .504	33 1.299	64.5 2.539	21.7 .854	66.7 2.626	36 1.417
5	50.6 1.992	41.1 1.618	37.5 1.476	28.8 1.134	21.6 .850	44 1.732	68.5 2.697	22.6 .890	70.7 2.783	46 1.811

Dimensions d1, d3, d4, e, b, l2 are identical with A and L type receptacle

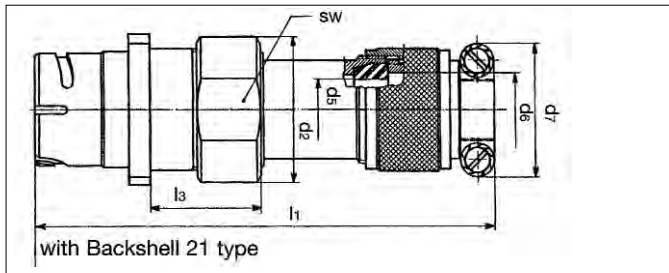

shell	d2 Max	d5 Max	d6 Max	d7 Max	l1 Max	l3 Max	sw
2	26.1 1.028	12.6 .496	13.1 .516	23.8 .937	82.3 3.240	20.3 .799	24 .945
4	38.6 1.520	19.1 .752	20.6 .811	33.8 1.331	98.1 3.862	21.7 .854	36 1.417
5	50.6 1.992	28.6 1.126	30.1 1.185	43.8 1.724	119.7 4.713	22.6 .890	46 1.811

Jam nut receptacle without thread for backfitting

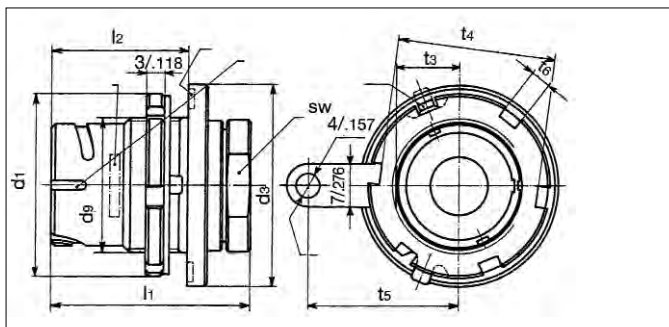

847 Series



Jam nut receptacle with thread for backfitting

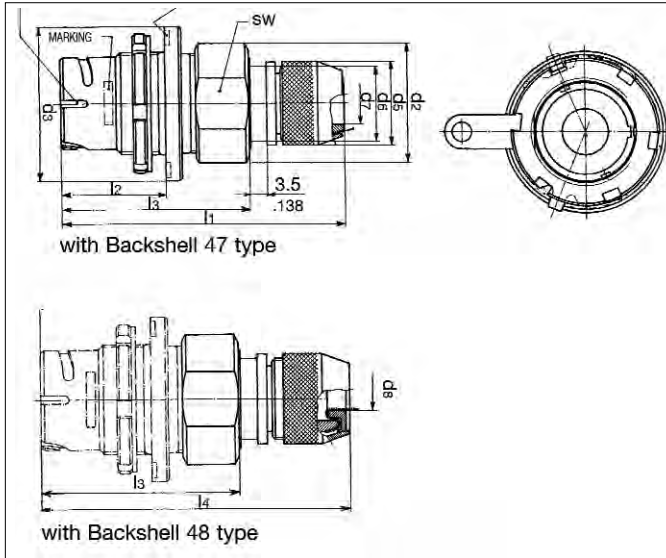

shell	d2 Max	d3 Max	d5 Max	d6	d7	d8	l1 Max	l2 Max	l3 Max	l4 Max	sw
2	26.1 1.028	33 1.299	18.1 .713	16.1 .634	9.2 .362	- -	61.1 2.406	22.5 .886	38.6 1.520	- -	24 .945
4	38.6 1.520	48 1.890	28.1 1.106	26.2 1.031	18.3 .720	12.8 .504	64.4 2.535	23.2 .913	41.2 1.622	66.6 2.622	36 1.417
5	50.6 1.992	59 2.323	41.1 1.618	37.5 1.476	28.8 1.134	21.6 .850	68.4 2.693	23.5 .925	44.9 1.768	70.7 2.783	46 1.811

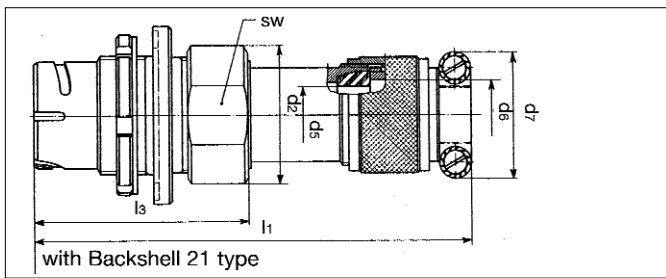

shell	d2 Max	d5 Max	d6 Max	d7 Max	l1 Max	l3 Max	sw
2	26.1 1.028	12.6 .496	13.1 .516	23.8 .937	82.3 3.240	38.6 1.520	24 .945
4	38.6 1.520	19.1 .752	20.6 .811	33.8 1.331	98.1 3.862	41.2 1.622	36 1.417
5	50.6 1.992	28.6 1.126	30.1 1.185	43.8 1.724	119.7 4.713	44.9 1.768	46 1.811

Plug F type

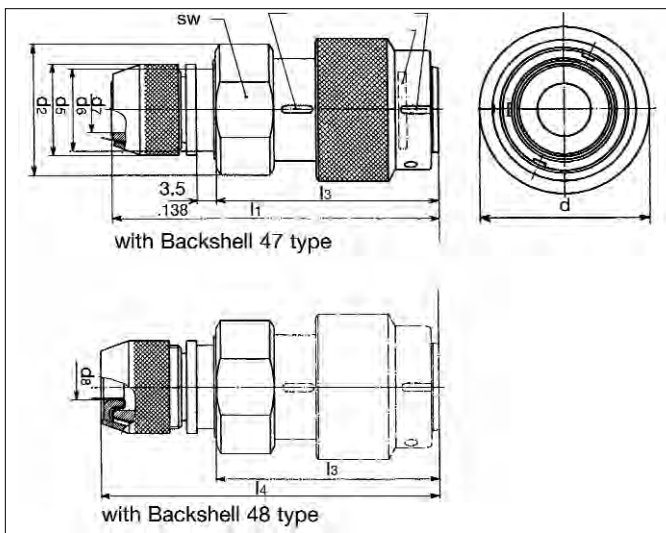

shell	d Max	d2 Max	d5 Max	d6	l3 Max	sw
2	28.6 1.126	26.1 1.028	18.1 .713	16.1 .634	44 1.732	24 .945
4	41.1 1.618	38.6 1.520	28.1 1.106	26.2 1.031	46.5 1.831	36 1.417
5	53.1 2.091	50.6 1.992	41.1 1.618	37.5 1.476	48.8 1.921	46 1.811

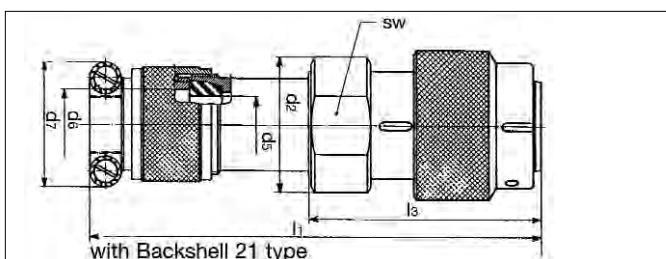

shell	d7	l1 Max	d8	l4 Max
2	9.2 .362	64.2 2.528	- -	- -
4	18.3 .720	67.7 2.665	12.8 .504	69.9 2.752
5	28.8 1.134	71.8 2.827	21.6 .850	74.1 2.917

shell	d2 Max	d5 Max	d6 Max	d7 Max	l1 Max	l3 Max	sw
2	26.1 1.028	12.6 .496	13.1 .516	23.8 .937	85.4 3.362	44 1.732	24 .945
4	38.6 1.520	19.1 .752	20.6 .811	33.8 1.331	101.4 3.992	46.5 1.831	36 1.417
5	50.6 1.992	28.6 1.126	30.1 1.185	43.8 1.724	123.0 4.843	46.8 1.843	46 1.811

847 Series



Cable connecting receptacle P type

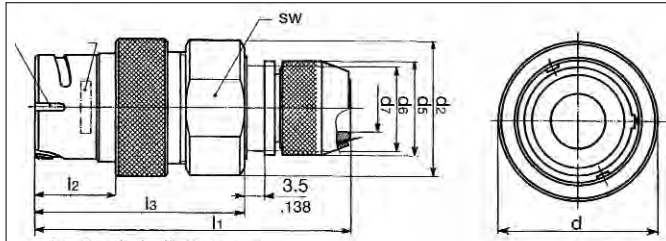

with Backshell 47 type

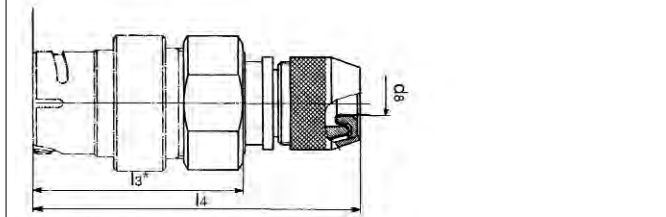

with Backshell 48 type

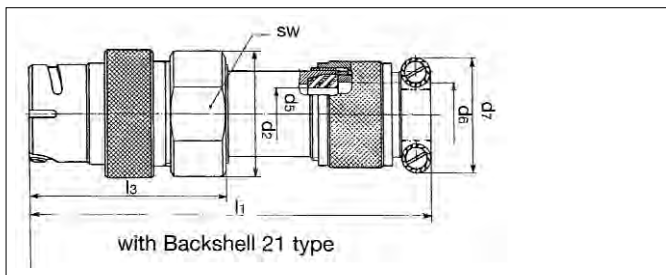

with Backshell 21 type

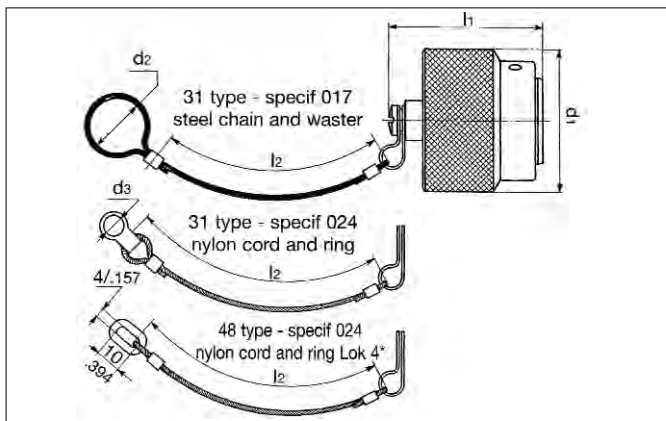

* Mounting with insulok (Hellermann) collar

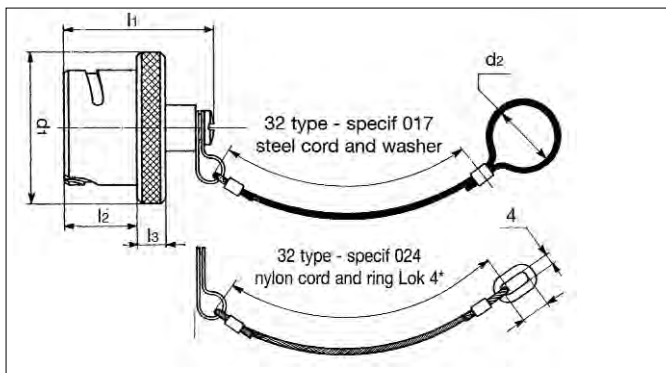

* Mounting with insulok (Hellermann) collar

shell	d	d2 Max	d5 Max	d6	l2	l3 Max	sw
2	26.5 1.043	26.1 1.028	18.1 .713	16.1 .634	15.5 .610	40.6 1.598	24 .945
4	39 1.535	38.6 1.520	28.1 1.106	26.2 1.031	16.4 .646	42.9 1.689	36 1.417
5	51 2.008	50.6 1.992	41.1 1.618	37.5 1.476	13.5 .531	45.1 1.776	46 1.811

shell	d7	l1 Max	d8	l4 Max
2	9.2 .362	60.9 2.398	-	-
4	18.3 .720	63.5 2.500	12.8 .504	65.7 2.587
5	28.8 1.134	68.2 2.685	21.6 .850	70.5 2.776

shell	d2 Max	d5 Max	d6 Max	d7 Max	l1 Max	l3 Max	sw
2	26.1 1.028	12.6 .496	13.1 .516	23.8 .937	82 3.228	40.6 1.598	24 .945
4	38.6 1.520	19.1 .752	20.6 .811	33.8 1.331	97.8 3.850	42.9 1.689	36 1.417
5	50.6 1.992	28.6 1.126	30.1 1.185	43.8 1.724	119.4 4.701	45.1 1.776	46 1.811

part numbers

8.45.20.0031.017
8.45.40.0031.017
8.45.50.0031.017

8.45.20.0031.024
8.45.40.0031.024
8.45.50.0031.024

8.45.20.0048.024
8.45.40.0048.024
8.45.50.0048.024

dim	2	4	5
d1 Max	26.6 1.047	39.1 1.539	51.1 2.012
d2	23 .906	34 1.339	46 1.811
d3	5 .197	5 .197	5 .197
l1 Max	31.5 1.240	31.5 1.240	34.5 1.358
l2	130 5.118	130 5.118	130 5.118

part numbers

8.45.20.0032.017
8.45.40.0032.017
8.45.50.0032.017

8.45.20.0032.024
8.45.40.0032.024
8.45.50.0032.024

dim	2	4	5
d1 Max	26.6 1.047	39.1 1.539	50 1.969
d2	23 .906	34 1.339	46 1.811
l1 Max	27 1.063	27.2 1.071	27.2 1.071
l2 Max	12.5 .492	13.2 .520	13.2 .520
l3 Max	5.1 .201	5.1 .201	5.1 .201
l4	130 5.118	130 5.118	130 5.118

847 Series

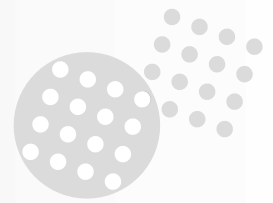

Cable stripping (for type 47 and 48 backshells)

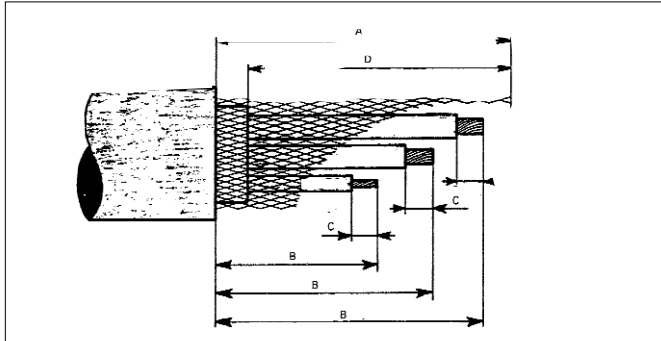

shell	A	D	type of cont.	B	C
2	50 1.969	40 1.575	ground	50 1.969	6.5 .256
			phase	45 1.772	
4	55 2.165	45 1.772	ground	55 2.165	6.5 .256
			phase	50 1.969	
			pilot	55 2.165	
5	70 2.756	50 1.969	ground	70 2.756	11 .433
			phase	65 2.559	
			pilot	70 2.756	6.5 .256

Crimping tools

shell	plier	turret	type of contact	turret position	section cable (mm ²)	selector position
2	M22520-1/01 (8365)	8400.2281	ground	red	1.34 à 1.50 1.91	6 7
			phase	blue	1.34 à 1.50 1.91	6 7
4	M22520-1/01 (8365)	8400.2282	ground	red	2.5 à 4.0	8
			phase	blue	2.5 à 4.0	8
			pilot	yellow	0.50 à 0.75	4
5	MS3191-1 (8465)	8400.2336	pilot	-	0.50 à 0.75	-
	M22520-1/01 (8365)	8400.2282		yellow	0.50 à 0.75	4
	8459	8459.129	ground phase	-	13.40	-

Extraction and insertion tools

shell	remark	type of contact	insertion tool male/female	extraction tool (male)	extraction tool (female)
2	-	phase	8400.1475	8400.448	8400.446
		ground			8400.322
4	without grommet	pilot	8500.29A	8500.31	8500.31
	with grommet		8400.2071		
	-	phase ground	8400.1475	8400.448	8400.322
5	-	pilot	8400.2071	8310.31	8310.31
	cable 5.15 mm ²	phase	8400.2428	8400.448	8400.980
			8380.02		
	-	ground	8400.1549	8400.1549	8400.1549

Cable

cable characteristics		shell 2	shell 4	shell 5
Ø over insulator Max	type 21 et 23 backshell	12.50 .492	19.00 .748	28.50 1.122
	type 47 backshell	9.10 .358	18.20 .717	28.70 1.130
	type 48 backshell	-	12.80 .504	21.60 .850
		-	-	-
Ø braid strands		0.20 .008	0.25 .010	0.40 .016
pilot wire	over insulator Max dia.	-	-	2.30 .091
	over insulator min dia.	-	-	1.80 .071
	section min (mm ²)	-	-	0.50 .0008
	section Max (mm ²)	-	-	0.75 .0012
ground and phase wires	over insulator Max dia.	3.30 .130	4.40 .173	8.00 .315
	over insulator min dia.	2.30 .091	3.10 .122	7.00 .276
	section min (mm ²)	1.34 .0021	2.50 .0039	13.40 .0208
	section Max (mm ²)	1.91 .0030	4.00 .0062	

Heat shrink sleeves (for type 47 and 48 backshells)

shell	straight-sleeve	bent-sleeve
2	202 K 132 - 4	222 K 132 - 4
4	202 K 163 - 4	222 K 163 - 4
5	202 K 174 - 4	222 K 174 - 4

